

SAILOR® 250 FLEETBROADBAND

COBHAM

The high-performance, affordable global connectivity and voice solution

2013 Product Sheet

The most important thing we build is trust

With data speeds up to 284 kbps from a compact, lightweight and simple to install antenna, SAILOR 250 FleetBroadband is the perfect balance between performance and price. It gives you fast data connectivity and voice simultaneously, allowing you to run online operational systems such as remote monitoring, whilst still having access to e-mail, intranet/internet and multiple voice lines.

Optimal connectivity

FleetBroadband offers unrivalled global performance and opens up a world of communication possibilities. With SAILOR 250 FleetBroadband you have fast connectivity between your vessel and shore, regardless of location or conditions. You can ensure the smooth running of your business, increase crew welfare by providing easy to manage internet access and voice calling or simply enjoy your time at sea with high quality internet and voice communication always available.

A world of applications

In addition to complete office communication functionality, VPN and use of IP applications, SAILOR 250 FleetBroadband can be used for dedicated tracking and telemetry applications. This advanced functionality can enhance efficiency by ensuring your support on shore has all the information they need, from real-time engine data for maintenance to position data for fleet tracking and management. Simple and secure installation SAILOR 250 FleetBroadband is fast and easy to install, so getting connected aboard a single vessel or an entire fleet is straightforward and cost-effective. The system is delivered with everything you need to get started in the box and because it is based on standard IP services

and features a clear user interface, connecting your computer, corporate network or phone system is simple and secure.

Multiple voice lines

With up to six simultaneous voice lines possible using Inmarsat Multi-voice, an important part of the SAILOR 250 FleetBroadband solution is the Thrane IP Handset. This advanced plug-and-play handset provides an intuitive user interface through a 2.2" TFT colour screen and features cutting-edge technology, such as a state-of-the-art echo cancellation and noise suppression software, for excellent audio clarity.

Communicate with confidence

SAILOR products are highly regarded by maritime professionals for their design and build quality, which results in excellent reliability. To support this, we guarantee fast and dependable service through our established network of On Board Service Centers (OSC). With OSC locations all around the world, service and support is always available, whenever and wherever it is needed.



SAILOR® 250 FLEETBROADBAND

The high-performance, affordable global connectivity and voice solution

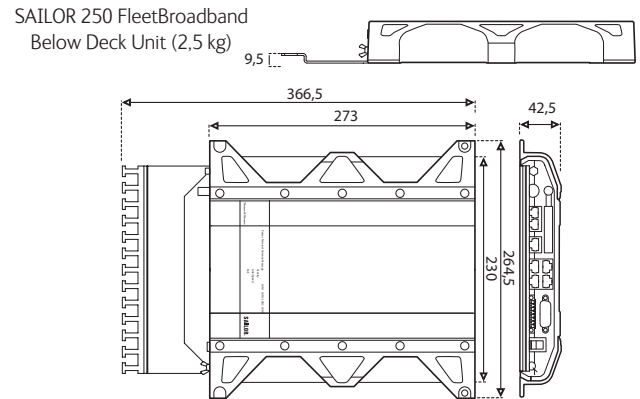
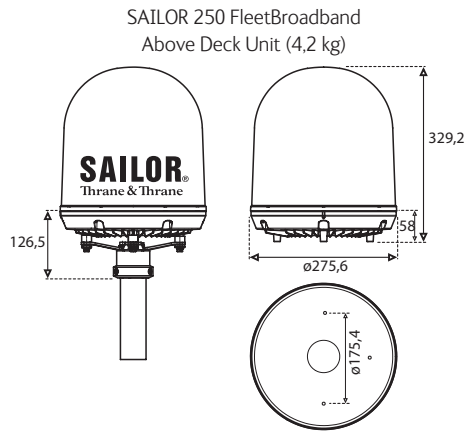

APPROVALS

Inmarsat FleetBroadband approved. Compliant to RTTE, CE Marked. Testet to FCC part 25

FREQUENCY BAND

Rx	1525.0 - 1559.0 MHz
Tx	1626.5 - 1660.5 MHz
Ch. width	10.5 - 189 kHz, Rx 21 - 189 kHz, Tx

RECOMMENDED ANTENNA CABLE

Cable loss max/min	20 dB at 1.62 GHz and 1.0 Ω DC loop resistance 3 dB at 36 MHz - 4 dB at 54 MHz
--------------------	---

POWER SUPPLY AND CONSUMPTION

DC input range (isolated)	10 to 32V DC
Power (max), incl. antenna & PoE output	150 W @ 10-32V

ENVIRONMENTAL CONDITIONS

Ambient Temperature	-25 to +55 °C
Storage	-40 to +85 °C
Survival (power on, non functional)	-40 to +80 °C
Automatic thermal surveillance shuts down system gradually in ease of own temperature	
BDU operating humidity	95% non-condensing at +40 °C
ADU enclosure	IPX6
ADU operating humidity	"Exposed" according to EN60 945
BDU enclosure	IP31
Icing (survival)	Max 25 mm

VIBRATION (ADU)

Vibration, operational	Random spectrum 1.05 g rms x 3 axes: 5 to 20 Hz: 0.02 g ² /Hz 20 to 150 Hz: -3 dB/octave
Vibration, non-operational	Random spectrum 1.7 g rms 2 h x 3 axes (6 h total): 5 to 20 Hz: 0.05 g ² /Hz 20 to 150 Hz: -3 dB/octave

SHIP MOTION

Roll	+/- 30 deg. per. 4 s, max. 0.7 g tan.
Pitch	+/- 15 deg. per. 3 s, max. 0.6 g tan.
Yaw	+/- 10 deg. per. 5 s, max. 0.3 g tan.
Surge	+/- 0.5g
Sway	+/- 0.5g
Heave	+/- 0.7g
Turning rate	+/- 36°/s; Acc. 12°/s ²
Headway speed	22 m/s (42 knots)
Wind	100 knots

ANTENNA CONNECTOR

ADU	TNC, female
BDU	TNC, female

MECHANICAL SHOCK

20g/11 half-sine

COMPARISON CHART

	SAILOR 500 FleetBroadband	SAILOR 250 FleetBroadband	SAILOR 150 FleetBroadband
Standard IP	Up to 432 kbps	Up to 284 kbps	Up to 150 kbps
Streaming IP	8, 16, 32, 64, 128, 256 kbps	8, 16, 32, 64, 128 kbps	-
ISDN Data	64 kbps	-	-
Fax	G4 via UDI, G3 fax via 3.1 kHz Audio	G3 fax via 3.1 kHz Audio	G3 fax via 3.1 kHz Audio
SMS (standard 3G)	160 characters	160 characters	160 characters
Standard Voice	4 kbps	4 kbps	4 kbps
Premium Voice	3.1 kHz Audio, 64 kbps	3.1 kHz Audio, 64 kbps	3.1 kHz Audio, 64 kbps
Multi-voice	9 voice lines simultaneously	6 voice lines simultaneously	4 voice lines simultaneously
Ethernet/PoE	4 ports	4 ports	2 ports
Phone/Fax (2-wire)	2 ports	2 ports	1 port
ISDN	1 port (data/3.1 kHz Audio)	1 port (3.1 kHz Audio)	-
I/O Connector	1 connector with 5 configurable inputs/outputs	1 connector with 5 configurable inputs/outputs	1 connector with 5 configurable inputs/outputs
L-Band Output	1 port for L-Band Broadcast service	1 port for L-Band Broadcast service	1 port for L-Band Broadcast service
Status LED	Full status LED panel	Full status LED panel	Full status LED panel
SIM Card Slot	1 SIM Card slot for BGAN SIM card	1 SIM Card slot for BGAN SIM card	1 SIM Card slot for BGAN SIM card
Router	Integral DHCP/NAT router	Integral DHCP/NAT router	Integral DHCP/NAT router
PBX	Built-in PBX	Built-in PBX	Built-in PBX

For further information please contact:

Cobham SATCOM Marine
Lundtoftegaardsvej 93 D
DK-2800 Kgs. Lyngby
Denmark
www.cobham.com
Tel: +45 3955 8800
Fax: +45 3955 8888